

Part #17483

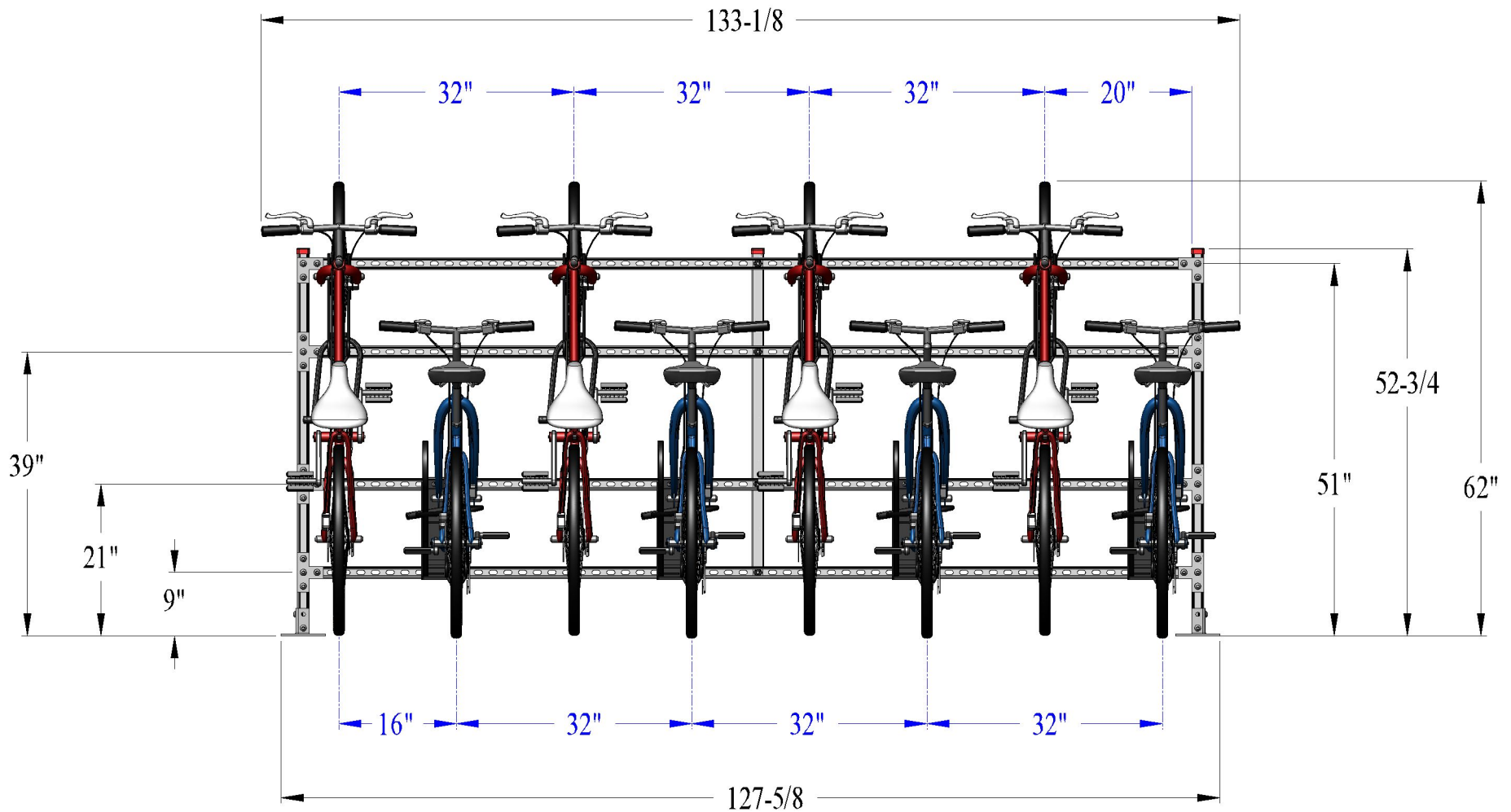

Bike Stall {8-Bike} H-Strut  
Post Base {Hi-Lo} Master {Iso}

Part #17483



Bike Stall {8-Bike} H-Strut  
Post Base {Hi-Lo} Master {Front} Dim's

Part #17483

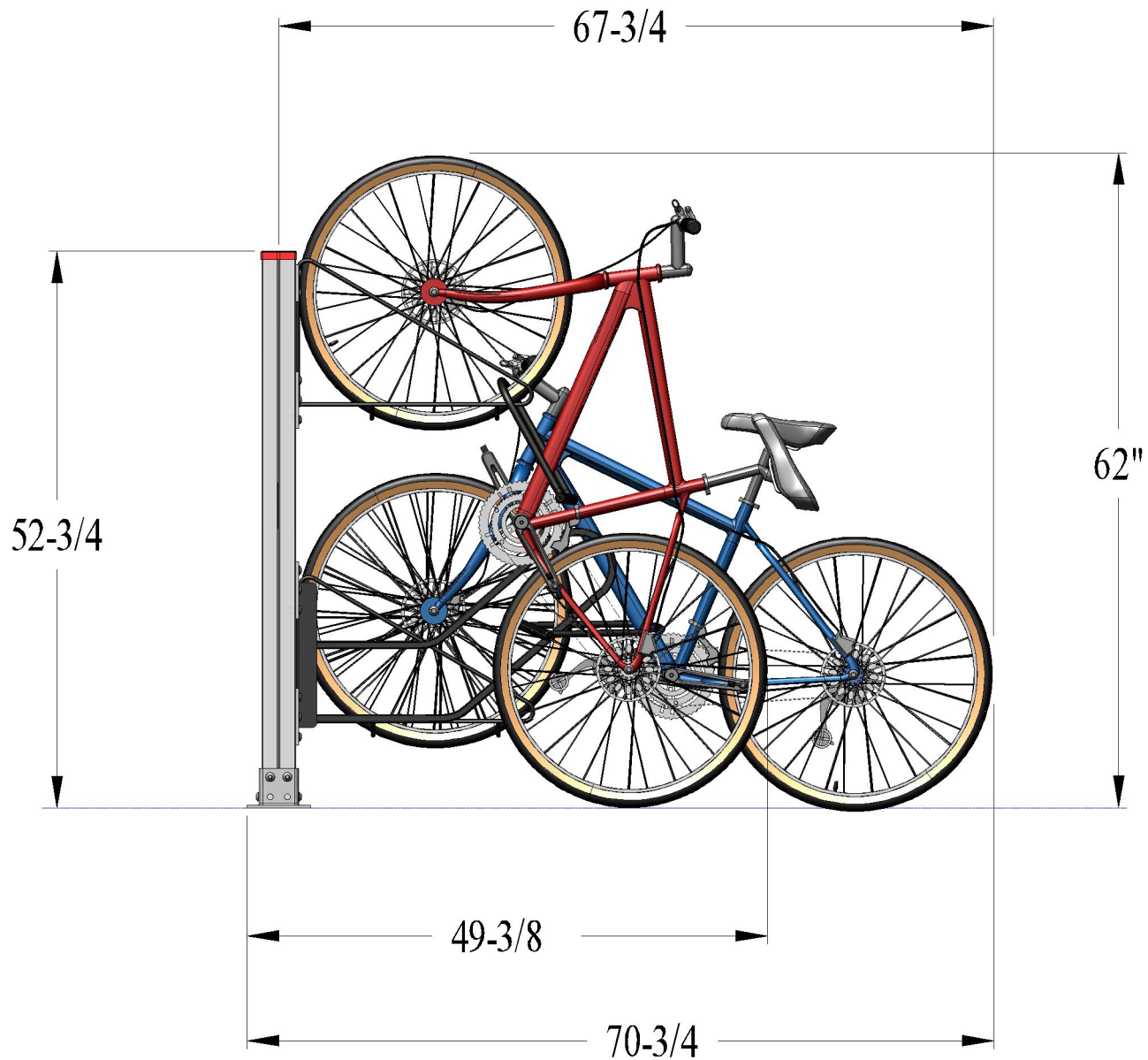

Bike Stall {8-Bike} H-Strut  
Post Base {Hi-Lo} Master {Side} Dim's

Part #17483

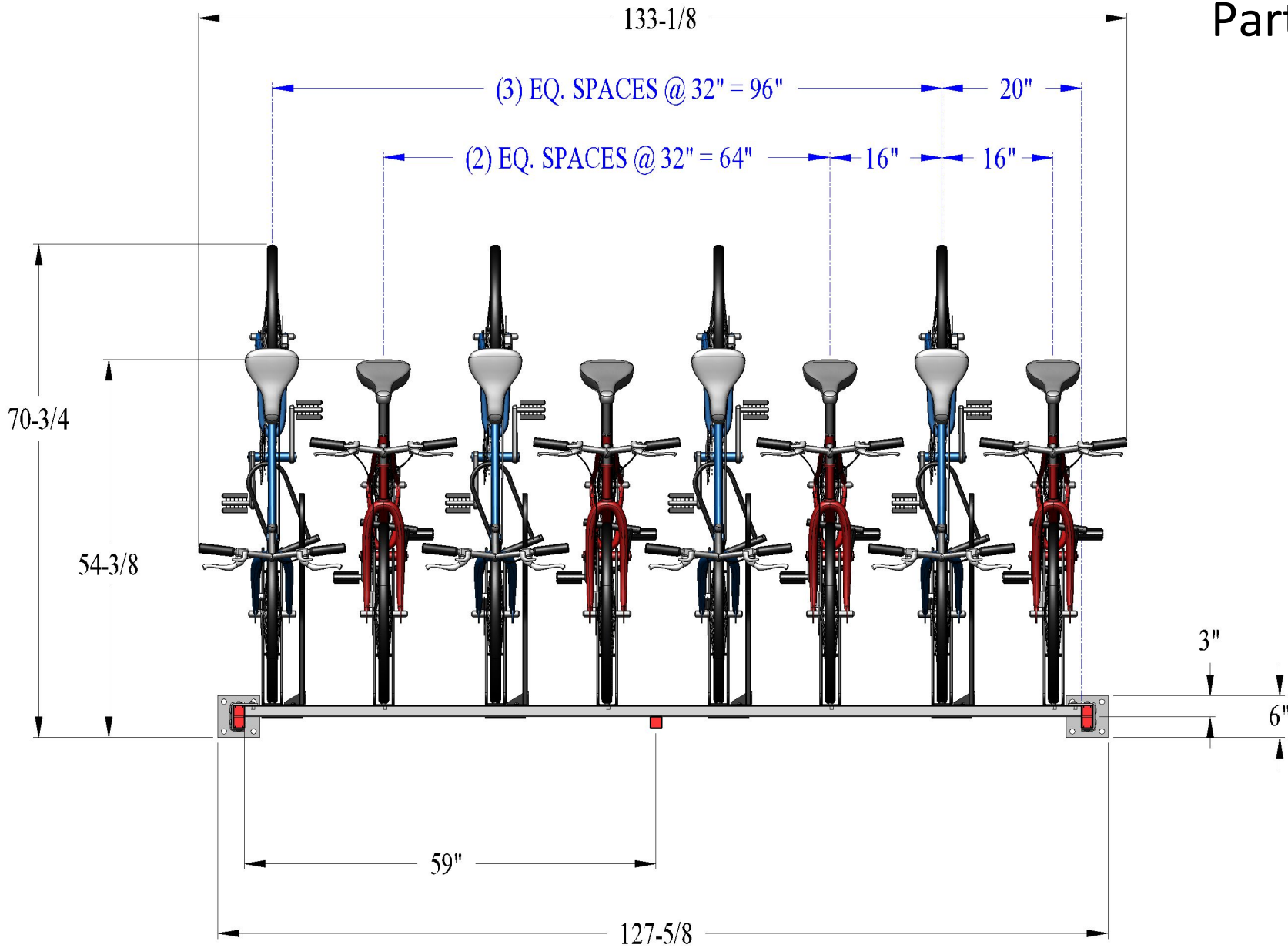

Bike Stall {8-Bike} H-Strut  
Post Base {Hi-Lo} Master {Top} Dim's

Part #17483

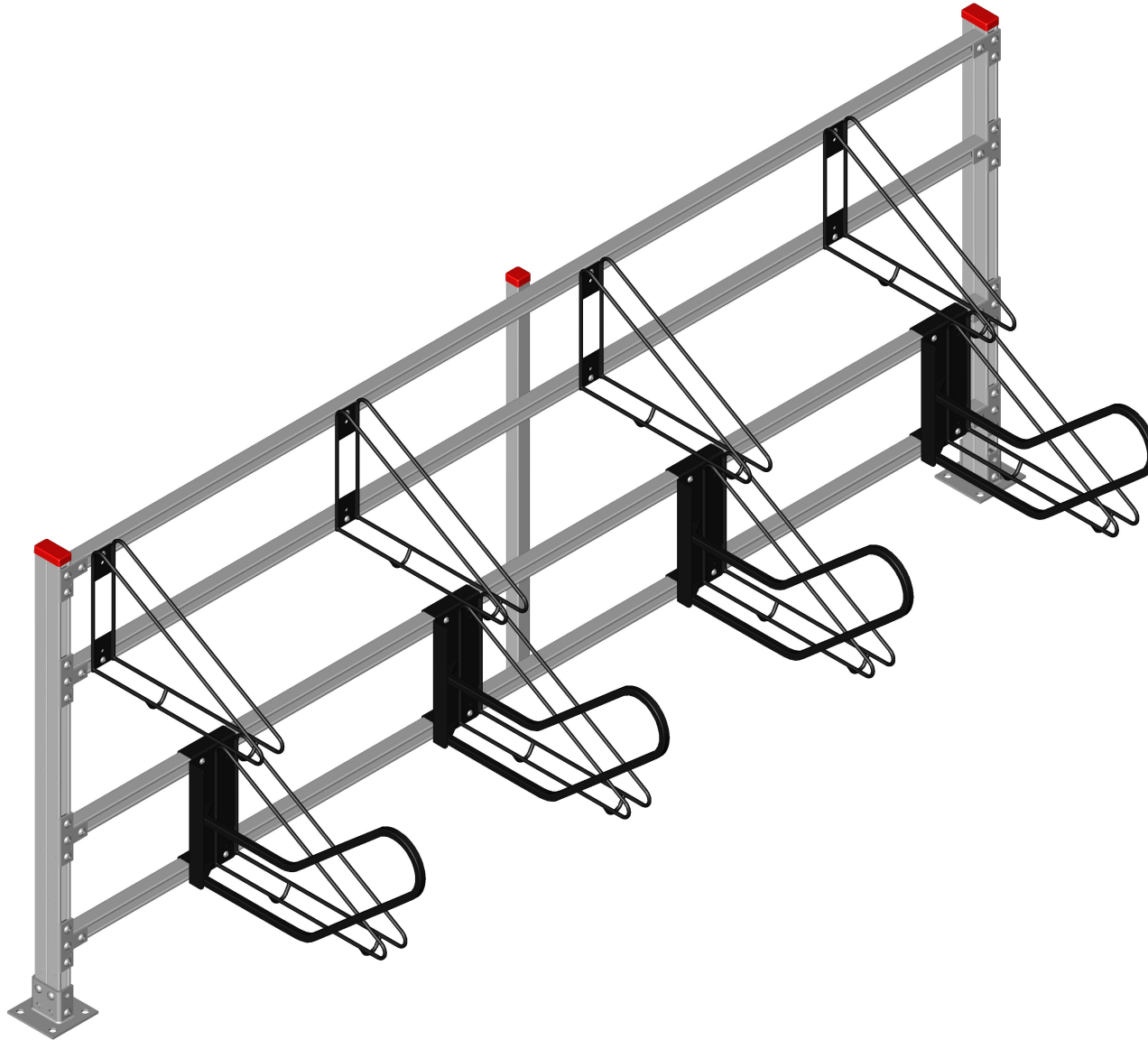

Bike Stall {8-Bike} H-Strut  
Post Base {Hi-Lo} Assembly {Iso}

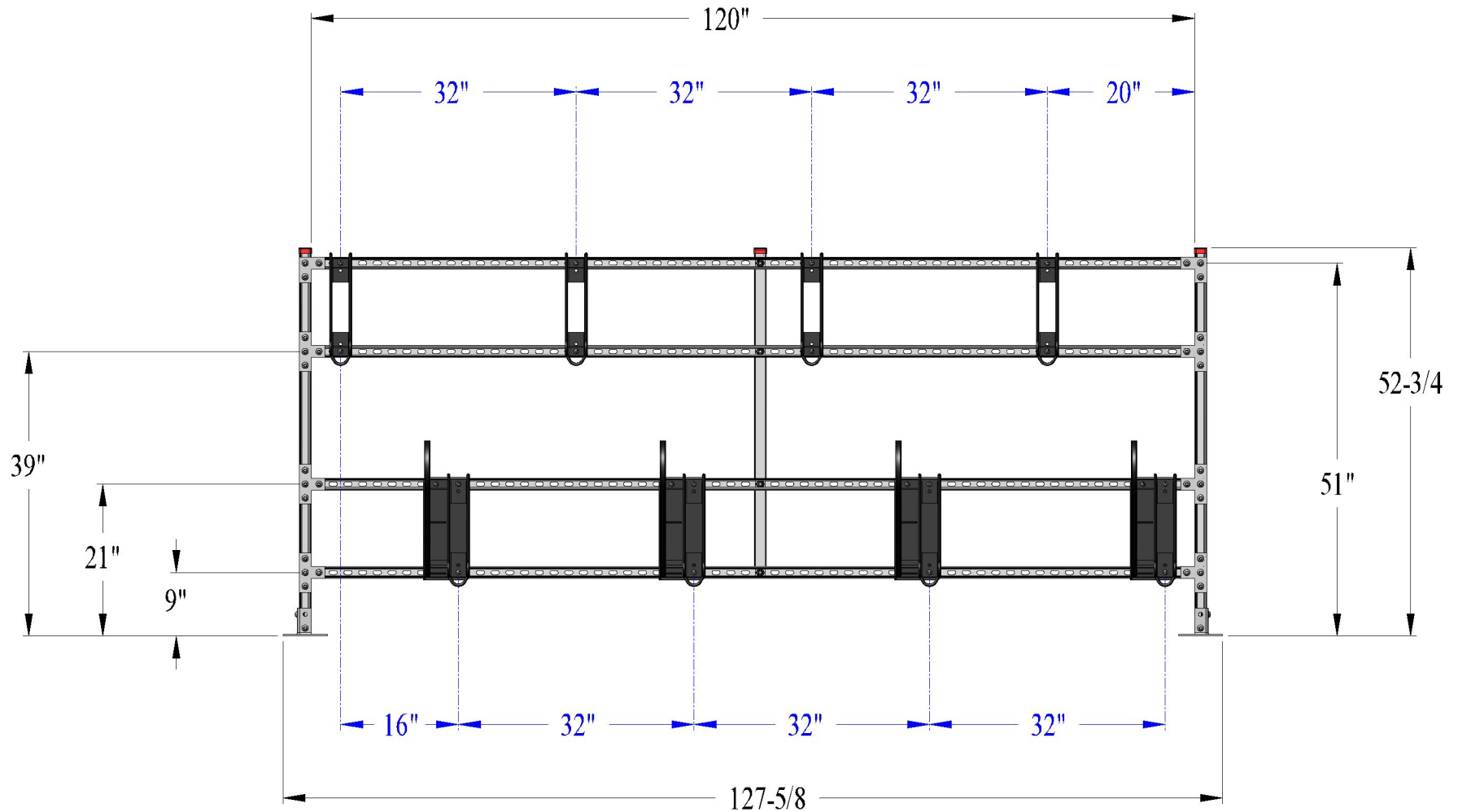

Bike Stall {8-Bike} H-Strut  
Post Base {Hi-Lo} Assembly {Front} Dim's

Part #17483

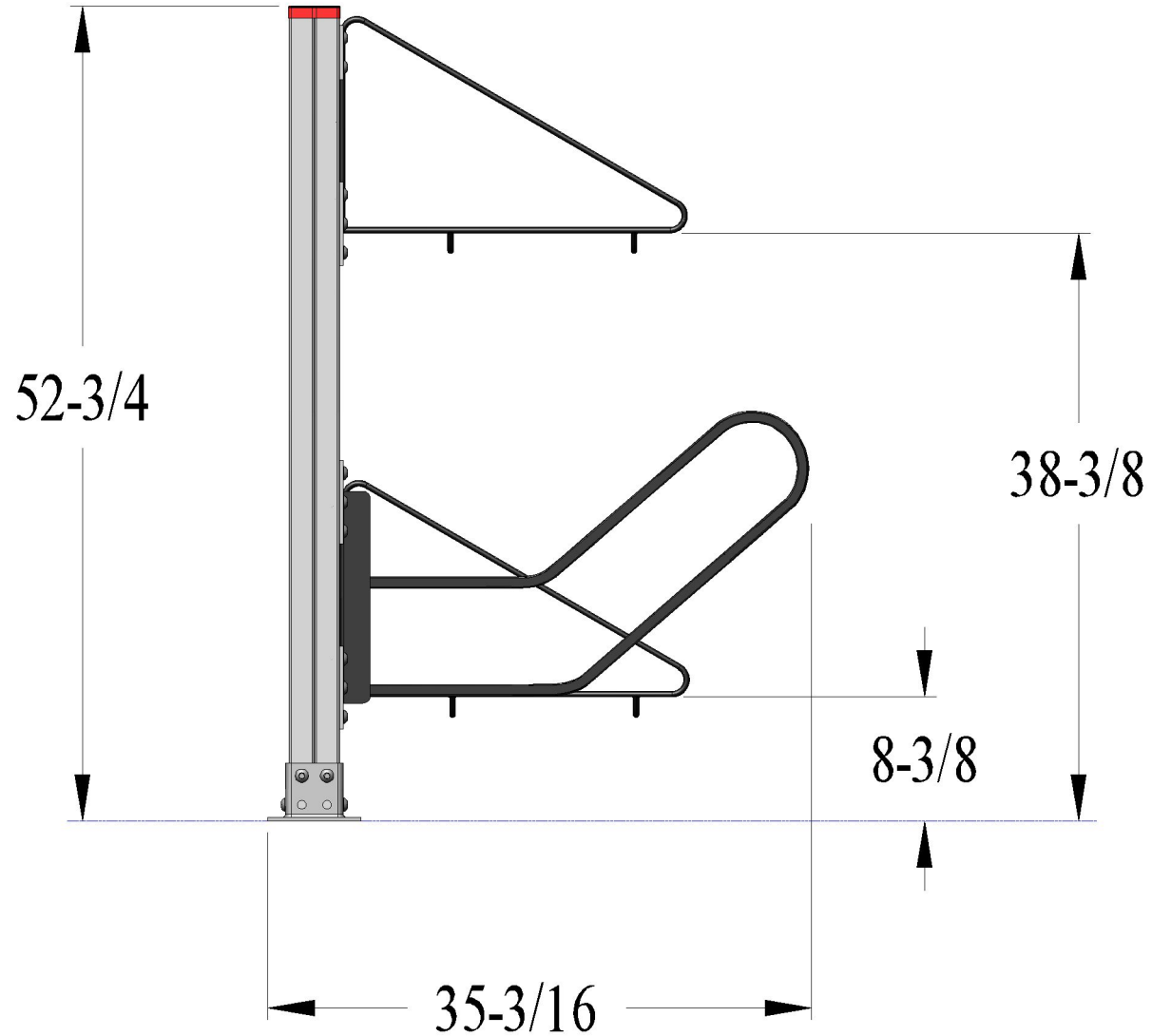

Bike Stall {8-Bike} H-Strut  
Post Base {Hi-Lo} Assembly {Side} Dim's

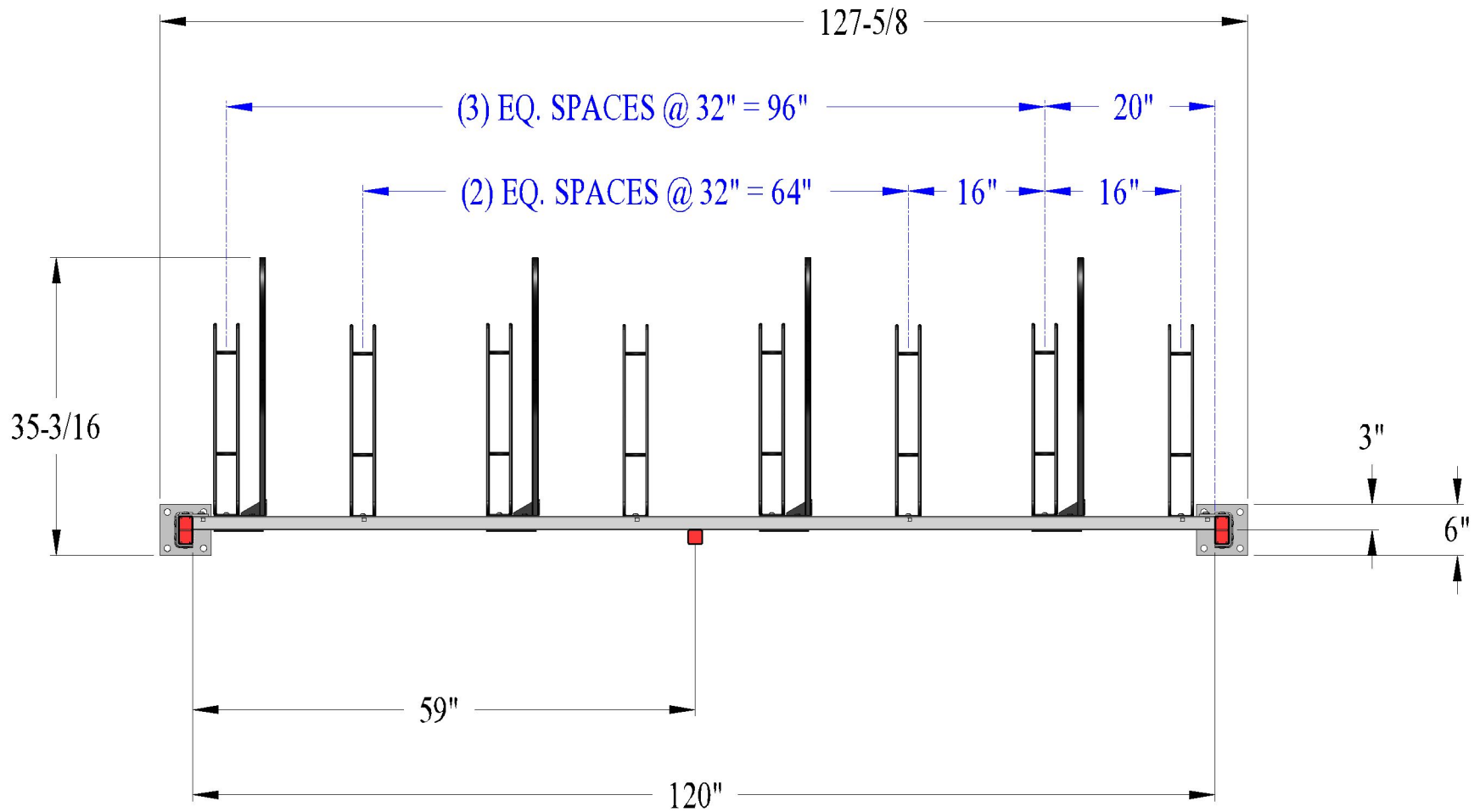

Bike Stall {8-Bike} H-Strut  
Post Base {Hi-Lo} Assembly {Top} Dim's



Part #17483

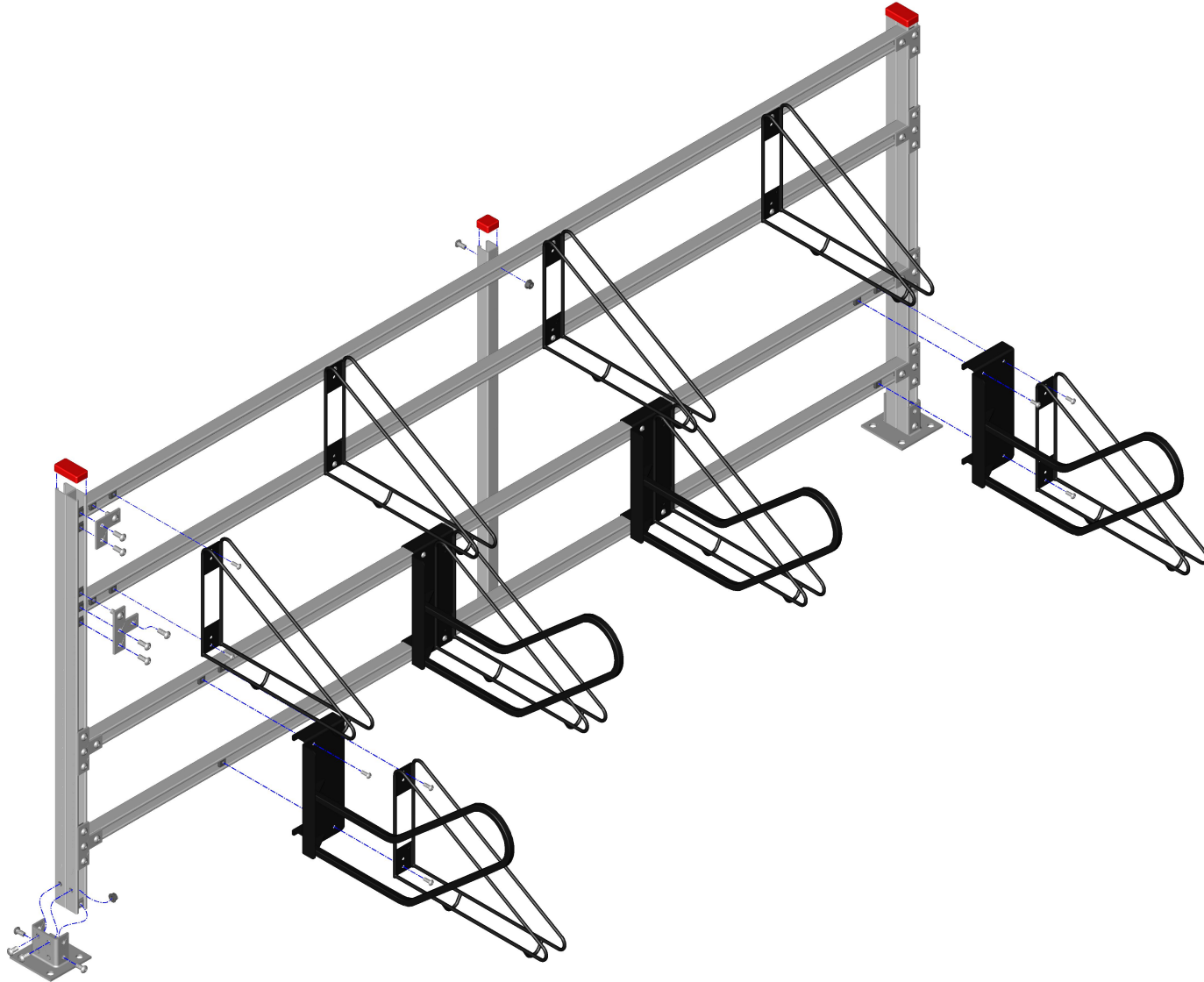

Bike Stall {8-Bike} H-Strut  
Post Base {Hi-Lo} Assembly {Exploded}

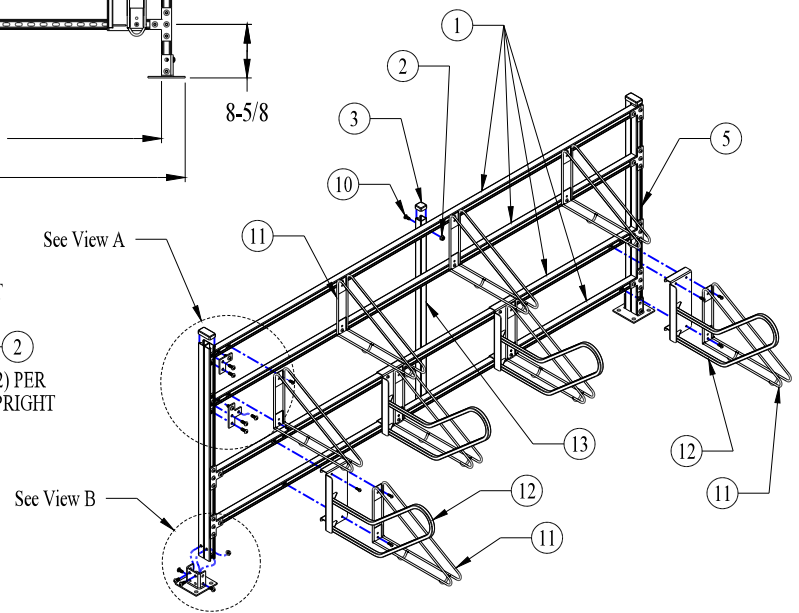
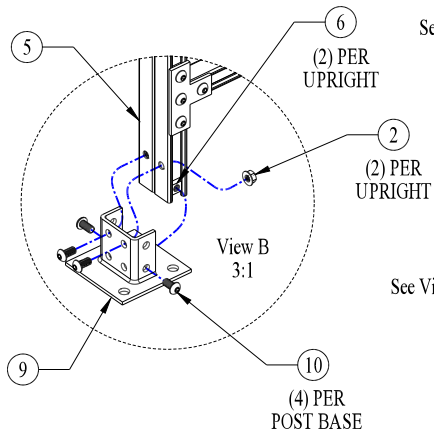
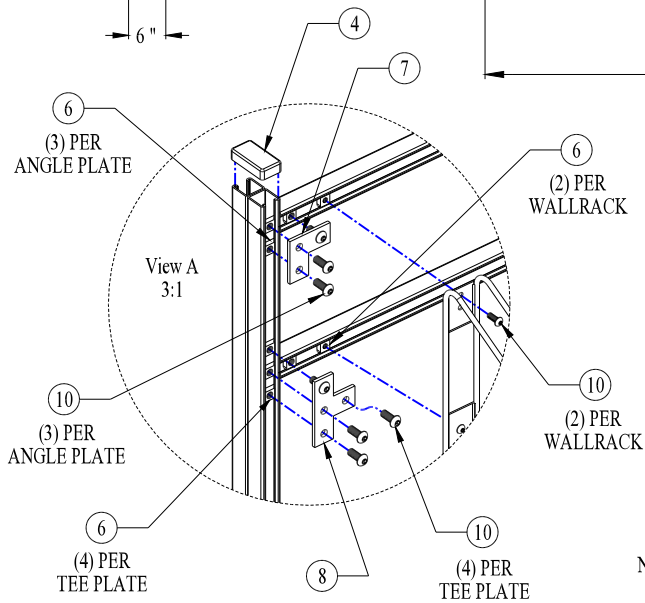
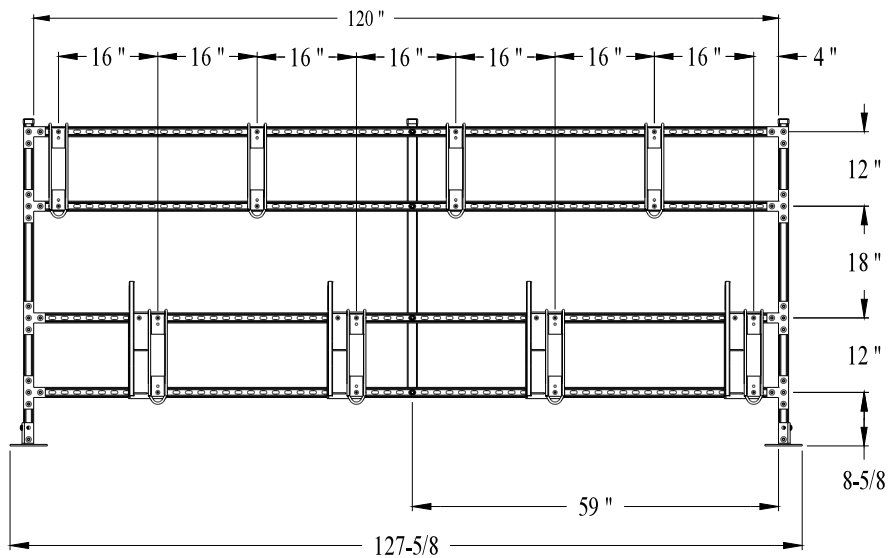
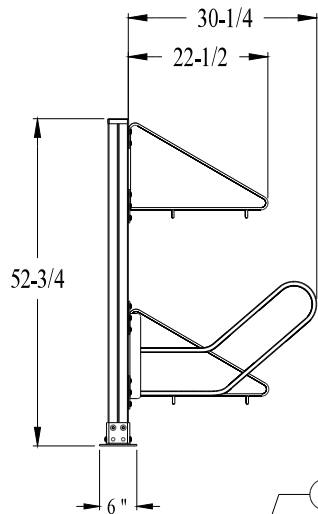

ITEM	QTY	DESCRIPTION	PART NO.
1	4	U-STRUT {SLOTTED} SPANNER x 120" LG.	17592
2	8	3/8-16NC SERRATED FLANGE NUT {ZINC}	19567
3	1	U-STRUT {PLASTIC} END CAP	17530
4	2	H-STRUT {PLASTIC} END CAP	17551
5	2	H-STRUT {PLAIN} UPRIGHT x 52-3/8" LG.	17597
6	54	3/8-16NC STRUT {ZINC} NUT	17525
7	2	ANGLE PLATE	17528
8	6	TEE PLATE	17524
9	2	H-STRUT {POST} BASE	17485
10	62	3/8-16NC x 1" LG. {TORX} S/S BHCS	12724
11	8	WALL-RACK	17502
12	4	LOCK BAR WELDMENT	17549
13	1	U-STRUT {PLAIN} VERTICAL x 44-5/8" LG.	17579

**NOTES:**

1. ALL MATERIALS MUST BE CLEAN AND FREE OF MILL LUBRICATION
2. ANY BLEMISHES OR RUST WILL NOT BE ALLOWED ON COMPLETED PRODUCTS
3. FOR "TAMPERPROOF" FASTENERS: USE 3/8 S/S TORX {PINNED} BHCS (17590) IN PLACE OF ITEM #10

**SINGLE-SIDED  
HIGH DENSITY**

SHEET 1 OF 1		B	REDRAWN WITH CHANGES	10/18/13
		A	RELEASE FOR PRODUCTION	11/02/12
		REV	DESCRIPTION	DATE
TOLERANCES UNLESS OTHERWISE SPECIFIED: +/-		WALL-RACK {CORRAL} H-STRUT {HI-LO}		
		<b>Cycle Safe</b>		
		5211 CASCADE RD SE, SUITE 210 GRAND RAPIDS, MI 49546 www.cyclesafe.com		
		GERI MOHR	11/02/12	
		BOB SLYH	10/18/13	
		APPROVED	DATE	
		POST BASE {8-BIKE} ASSEMBLY		17483
				B